

STALA
TUBE



DATASHEET **METRIC**

Stainless steel lightweight solutions
for transportation industry

Stalatube stainless steel lightweight solutions

Tubes, sheets and components for bus bodies, chassis, collision guards and cabin structural parts

Stalatube's product portfolio contains standard and fully custom-made square and rectangular tubes, tube components, sheets, and welded structures. Laser cutting, bending, and creating ready-to-assemble component kits are at the core of our services for the transport industry. Lead time is reduced through flexible stocking and delivery options.

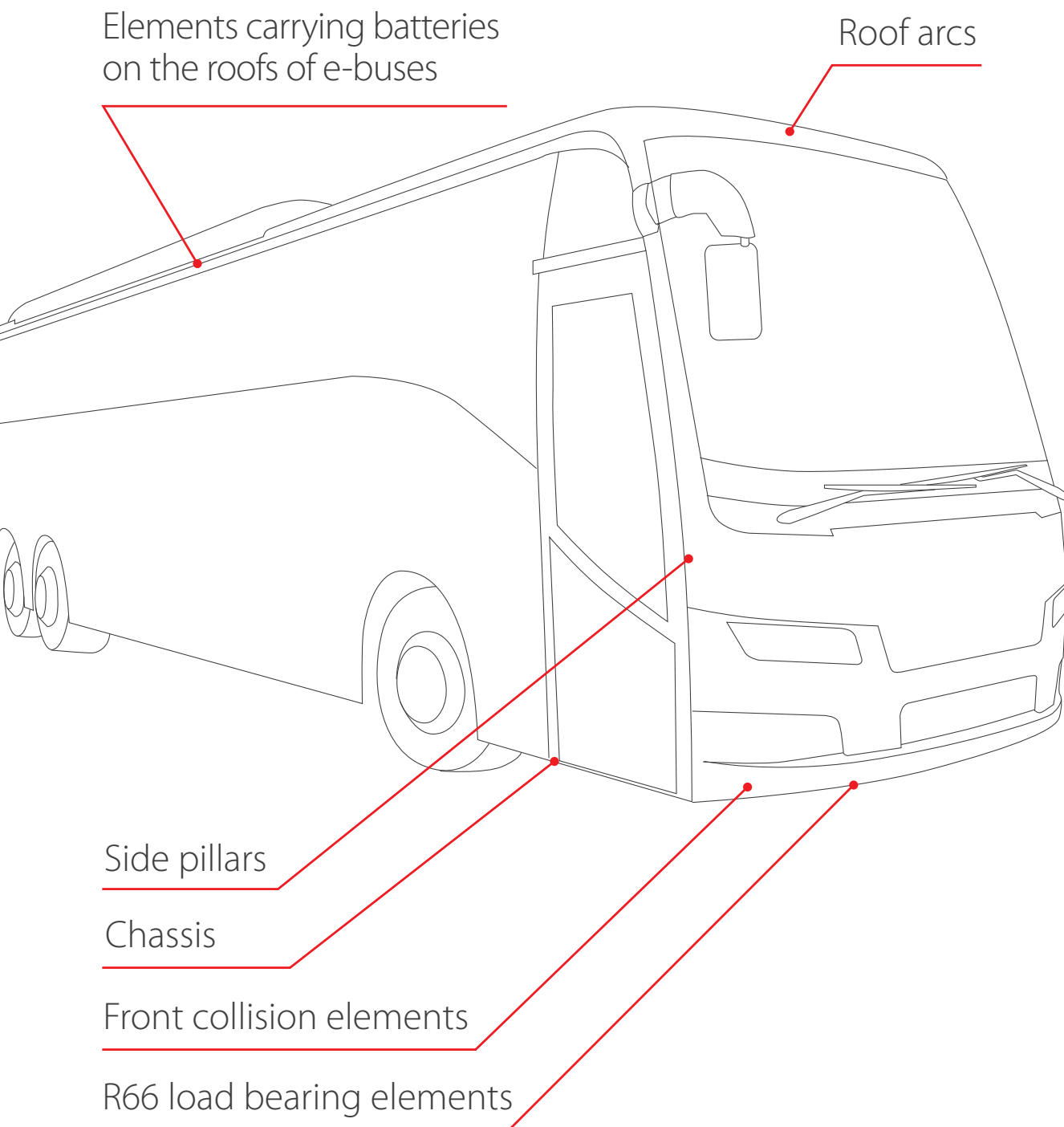

Stainless steel lightweight solutions

In transportation sector the ultimate goal is clear – lighter vehicles with lower CO₂ emissions paired with the very highest occupant safety. Stalatube's innovative high strength stainless steel materials and optimal vehicle structure design help achieve the weight reduction necessary as well as to meet CO₂ goals.

Achieve your carbon footprint goals

Stainless steel is 100% circular. It is the most recycled material in the world, and its quality is preserved in the process. Using stainless steel decreases your own as well as your customer's carbon footprint.

About Stalatube

Stalatube is a manufacturer of highly developed stainless steel hollow sections, profiles and components. We are known worldwide as the leading provider of stainless steel solutions. With a global presence, in-depth material expertise and the world's widest product portfolio in stainless square and rectangular hollow sections, we help customers connect the most suitable product with their application or project - in even the most complex of cases. Our customizable, environmentally conscious solutions are here to build a better future. We believe that by working with customers and investing in R&D, anything is possible.

For over 50 years of pioneer work in the industry, we have built an international distribution network covering all continents and over 50 countries. Our head office and main production facility are in Finland, sales offices are in the USA and the Netherlands, an R&D office in Turkey, and a production facility for further processed products in Poland. To assist you in being the best, we provide world-class stainless steel expertise, cutting-edge technology and a full range of professional services.

USE OUR STRENGTH!



Use our special consultation service

How to design the most lightweight bus body?

Our team has a long technical experience and know-how in bus body design. Major savings in total weight of a vehicle can be achieved by optimizing the bus body structure. We are here to help our customers to choose the right materials and products to maximize the benefits of stainless steel.

Tolerances

Cut to length service	4-18 m, tolerance -0/+20 mm
Precise cutting	20-9000 mm, tolerance ± 1 mm ≥ 9000 mm, tolerance depends on the length
Angle cutting	30-90°, tolerance $\pm 1^\circ$
Laser cutting	Tolerance ± 0.5 mm

Mechanical properties

Mechanical properties of tubes						
Strength class	Steel grade	EN	UNS	0.2 % - proof strength Rp0.2 MPa	Tensile strength Rm MPa	Elongation in 2 in. or 50 mm min., %
Standard 1.4003	4003	1.4003	S40977	280	450	10
STALA400F	4003	1.4003	S40977	400	450	10
Standard 1.4162 T > 5 mm	LDX2101	1.4162	S32101	450	650	20
STALA630D	LDX2101	1.4162	S32101	630	750	20
STALA800	H800	1.4678	-	800	1000	25
Sheets	4003	1.4003	S40977	280	450-650	20
Sheets	LDX2101	1.4162	S32101		650-900	30

Chemical composition

Chemical composition (% by mass, maximum values unless indicated otherwise)												
Steel grade	EN	UNS	C	Si	Mn	P	S	N	Cr	Mo	Ni	Other
4003	1.4003	S40977	0.030	1.00	1.50	0.040	0.015	0.030	10.5-12.5		0.30-1.00	
LDX2101	1.4162	S32101	0.040	1.00	4.00-6.00	0.040	0.015	0.20-0.25	21.0-22.0	0.10-0.80	1.35-1.70	Cu 0.10-0.80
STALA800	1.4678	-	0.20-0.40	1.00	14.0-18.0	0.045	0.015	0.20-0.40	12.0-16.0	-	-	-

Chemical composition and mechanical properties of material fulfill the standard EN 10088-2.

STALA Smart Solutions

Engineered stainless steel solutions enhancing strength, stiffness, fatigue performance, and safety

Our newest innovations, STALA Opti, STALA Connect, STALA Ultimate and STALA Flex, are designed to enhance bus body structures with optimized strength, fatigue resistance, and stiffness.

STALA Opti offers superior flexural strength and lightweight design, while STALA Connect significantly improves the fatigue strength of welded tube connections. STALA Ultimate is engineered to maximize roll-over safety, offering superior load transfer efficiency and enhanced bending resistance. STALA Flex enables the reliable connection of dissimilar stainless steel profiles.

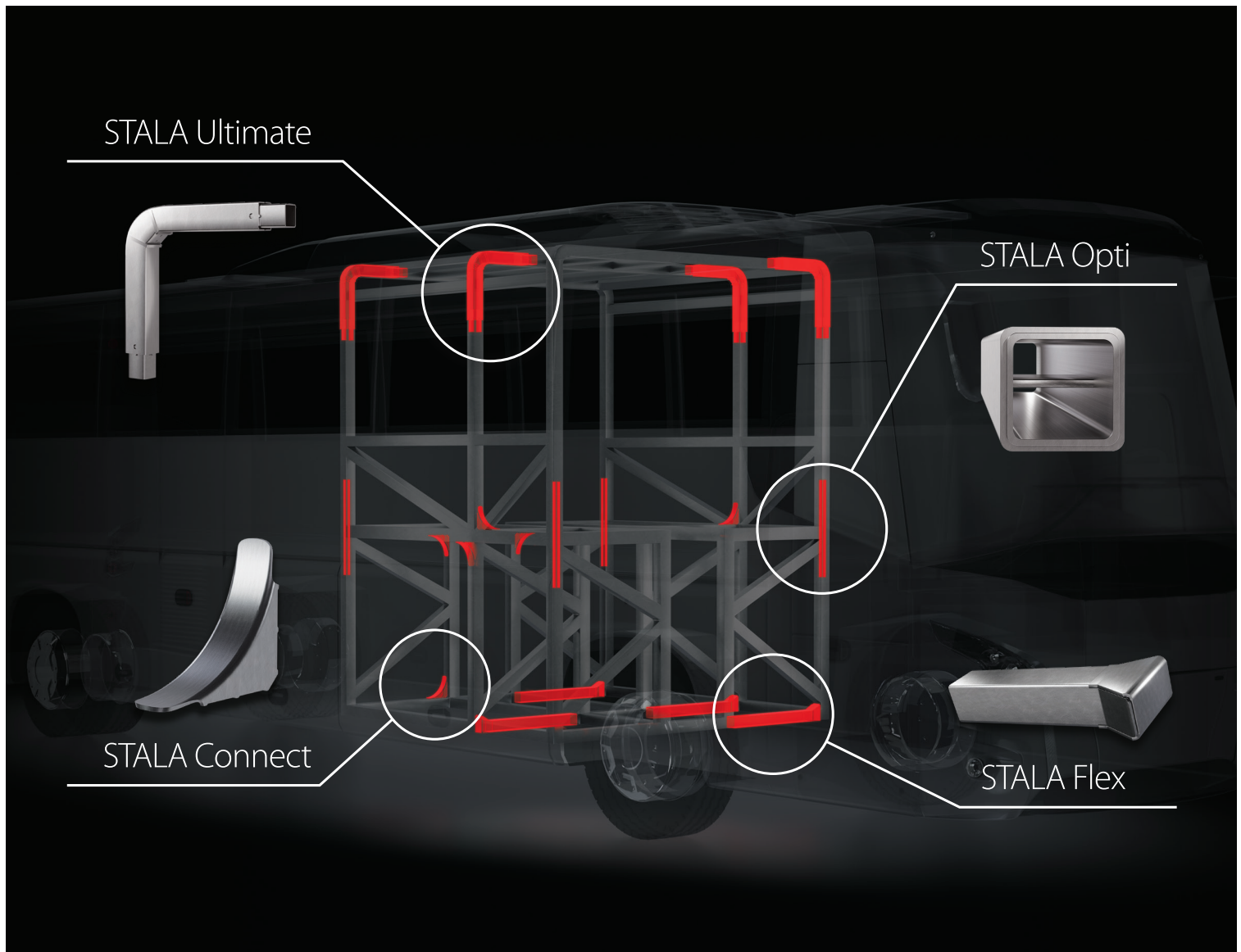

STALA Opti

The new reinforced tube with optimized strength, fatigue, and stiffness properties

The STALA Opti tube offers an excellent combination of flexural strength and light weight. Heavier wall thickness at the end of the tube allows better weld penetration and improved fatigue strength in welded tube joints. Reinforcement inside the tube significantly increases buckling resistance.

The optimal solution in those areas of the bus body structure where stiffness is required. STALA Opti offers excellent flexural strength for our customers looking for strength and durability without weight increase and stronger joints. This is a unique solution to strengthen the required area while eliminating the weight increase and is mainly suitable for bus body structures.

STALA Opti is available in all stainless steel grades in Stalalube's product portfolio.



High flexural strength and buckling resistance | Avoid problems related to welding of thin wall thicknesses | Big weight-saving potential



STALA Connect

Longer welding line, enhanced force distribution, and extreme fatigue life with joint parts

STALA Connect is designed to improve the fatigue strength of welded tube connections. It can be used in L, T and X joints. STALA Connect allows loads to be transferred further away from the joint. STALA Connect offers many times the fatigue strength of traditional joints.

30% increase in FAT class under bending loads
| Improved fatigue resistance

STALA Ultimate

Engineered for ultimate rollover safety

This patent-pending innovation delivers unmatched structural stiffness and energy absorption for bus body applications. Compared to S420 carbon steel, STALA Ultimate provides very higher stiffness and toughness in static and drop tower opening/closing test scenarios with significantly improved load transfer and bending resistance. Designed for maximum protection, it redefines safety and durability in lightweight stainless-steel structures.



Ultimate energy absorption

| High contribution to rollover safety | Extreme bend limits



STALA Flex

Simplifying complex connections with strength and flexibility

Designed to connect dissimilar stainless-steel profiles, STALA Flex enhances both durability and structural integrity at profile transitions. Delivering outstanding strength and stiffness beyond conventional methods, it ensures reliable, lightweight, and efficient structures for the next generation of buses.

Exceptional for dissimilar joints

| Better load transmission |

Ferritic

EN 1.4003

EN 1.4003 offers the benefits of more highly alloyed stainless steels such as strength, corrosion and abrasion resistance, durability and low maintenance. It is weldable and formable

allowing it to be fabricated using conventional techniques. Ferritic is also cost-efficient choice.

Delivery condition	
Forming	Cold formed (roll-formed)
Welding process	Laser or HF
Weld condition	External weld bead removed

Bundle packing	
Plastic bands	

Tube marking	
Ink-jet marking on tube	Stalutube Oy made in Finland, steel grade, dimensions, coil number, production week/year, welding operator
Bundle tag	Dimensions, steel grade, surface condition, bundle size, batch id, coil number, bundle number

Surface condition	
As welded (unpol)	

Tolerances (according to EN 10219-2)	
Characteristic	Tolerance
Outside dimensions, B and H	B, H < 100 mm: $\pm 1\%$, min ± 0.5 mm B, H ≥ 100 mm: $\pm 0.8\%$
Concavity / Convexity	Max. 0.8 % with minimum of 0.5 mm
Wall thickness, T	$\pm 10\%$
Squareness of side	$90^\circ \pm 1^\circ$
External corner profile (C1, C2 or R)	1.6T - 2.4T
Length	Standard length 6 m, tolerance 0/+20 mm ¹⁾
Straightness	0.15 % of total length
Twist	2 mm + 0.5 mm/m

¹⁾ Exception from standard

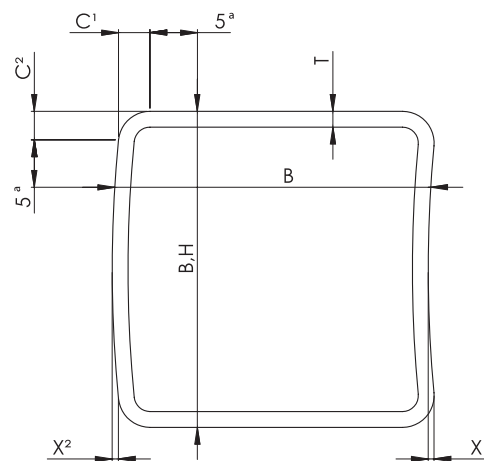
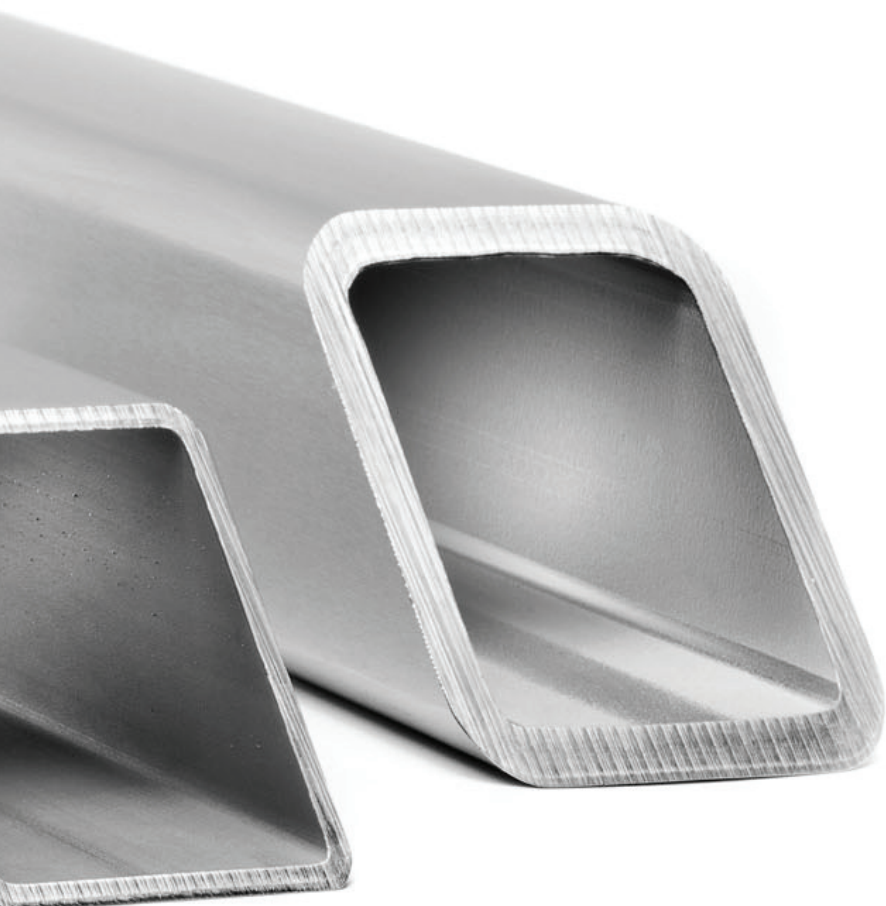

^a This dimension is maximum when measuring B or H and minimum when measuring T

Square		Weight [kg/m]						
H x B [mm]		1.5	2.0	2.5	3.0	4.0	5.0	6.0
20	20	0.810						
25	25	1.041	1.337					
30	30	1.272	1.645	1.993	2.316			
32	32	1.364	1.769	2.147	2.501			
35	35	1.503	1.953	2.378	2.778			
38	38	1.642	2.138	2.609	3.055	3.871		
40	40	1.734	2.261	2.763	3.240	4.117		
45	45	1.965	2.569	3.148	3.702	4.733		
50	50	2.196	2.877	3.533	4.164	5.349	6.433	
55	55	2.427	3.185	3.918	4.626	5.965		
60	60	2.658	3.493	4.303	5.088	6.581	7.973	
70	70		4.109	5.073	6.012	7.813	9.513	
75	75		4.417	5.458	6.474	8.429	10.283	
80	80		4.725	5.843	6.936	9.045	11.053	12.960
90	90			6.613	7.860	10.277	12.59	14.808
100	100				8.784	11.509	14.133	16.656

Sizes marked in **bold** are available in high-strength class STALA400F.

Rectangular		Weight [kg/m]						
H x B [mm]		1.5	2.0	2.5	3.0	4.0	5.0	6.0
30	20	1.041	1.337					
40	20	1.272	1.645					
40	25	1.388	1.799	2.186				
40	30	1.503	1.953	2.378	2.778			
50	20	1.503	1.953					
50	25	1.619	2.107	2.571				
50	30	1.734	2.261	2.763	3.240			
50	40	1.965	2.569	3.148	3.702			
60	20	1.734	2.261					
60	30	1.965	2.569	3.148	3.702			
60	40	2.196	2.877	3.533	4.164	5.349		
60	50		3.185	3.918	4.626	5.965		
70	40		3.185	3.918	4.626	5.965		
70	50		3.493	4.303	5.088	6.581		
80	30		3.185	3.918	4.626			
80	40		3.493	4.303	5.088	6.581		
80	50		3.801	4.688	5.550	7.197	8.743	
80	60		4.109	5.073	6.012	7.813	9.513	
100	30		3.801	4.688	5.550			
100	40		4.109	5.073	6.012	7.813		
100	50		4.417	5.458	6.474	8.429	10.283	
100	60		4.725	5.843	6.936	9.045	11.053	
100	80			6.613	7.860	10.277	12.593	14.808
120	40		4.725	5.843	6.936	9.045		
120	60				7.860	10.277	12.593	
120	80				8.784	11.509	14.133	16.656

Sizes marked in **bold** are available in high-strength class STALA400F.

Lean Duplex

EN 1.4162

EN 1.4162 grade answers to the most demanding needs by offering a superior combination of high strength and elongation, corrosion resistance and lowered life cycle costs.

Duplex is optimal material used in side pillars, roof arcs, R66 structures and collision guard elements. It can be combined with other materials such as ferritic EN 1.4003.

Delivery condition	
Forming	Cold formed (roll-formed)
Welding process	TIG/Plasma or Laser
Weld condition	External weld bead removed

Bundle packing	
Plastic bands	

Tube marking	
Ink-jet marking on tube	Stalatube Oy made in Finland, steel grade, dimensions, coil number, production week/year, welding operator
Bundle tag	Dimensions, steel grade, surface condition, bundle size, batch id, coil number, bundle number

Surface condition	
Brushed, when tube dimension is $\leq 100 \times 100 \times 6$ mm	
As welded (unpol), when tube dimension is $> 100 \times 100 \times 6$ mm	

Tolerances (according to EN 10219-2)		
Characteristic	Tolerance	
Outside dimensions, B and H	B, H < 100 mm: $\pm 1\%$, min ± 0.5 mm B, H ≥ 100 mm: $\pm 0.8\%$	
Concavity / Convexity (X^1/X^2)	Max. 0.8 % with minimum of 0.5 mm	
Wall thickness, T	$\pm 10\%$	
Squareness of side	$90^\circ \pm 1^\circ$	
External corner profile, C1, C2 or R	B+H ≤ 200 mm: 1.6T – 2.4T B+H > 200 mm and T ≤ 4 mm: 2.0T – 3.0T B+H > 200 mm and T > 4 mm: 1.6T – 2.4T	¹⁾
Length	Standard length 6 m, tolerance 0/+20 mm	¹⁾
Straightness	0.15 % of total length	
Twist	2 mm + 0.5 mm/m	

¹⁾ Exception from standard

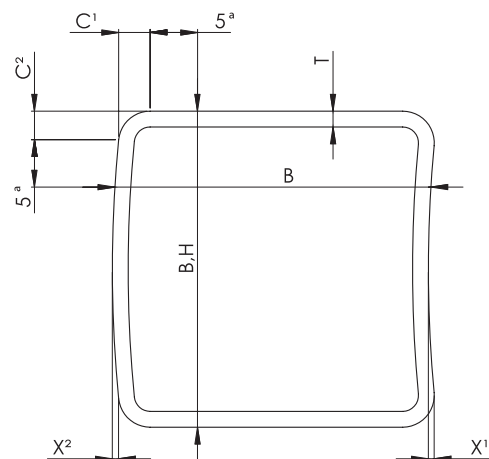

^a This dimension is maximum when measuring B or H and minimum when measuring T

Square		Weight [kg/m]						
H x B [mm]		1.5	2.0	2.5	3.0	4.0	5.0	6.0
25	25	1.055	1.355					
30	30	1.289	1.667	2.019				
32	32	1.382	1.792	2.175				
35	35	1.523	1.979	2.409				
38	38	1.663	2.166	2.643				
40	40	1.757	2.291	2.799	3.282			
45	45	1.991	2.603	3.189	3.750			
50	50	2.225	2.915	3.579	4.218	5.419		
55	55	2.459	3.227	3.969	4.686			
60	60	2.693	3.539	4.359	5.154	6.667		
70	70		4.163	5.139	6.090	7.915		
75	75		4.475	5.529	6.558	8.539		
80	80		4.787	5.919	7.026	9.163	11.197	
90	90			6.699	7.962	10.411	12.757	
100	100			7.479	8.898	11.659	14.317	16.872
120	120				10.770	14.155	17.437	20.616
150	150				13.578	17.899	22.117	26.232

Sizes marked in **bold** are available in high-strength class STALA630D.

Rectangular		Weight [kg/m]						
H x B [mm]		1.5	2.0	2.5	3.0	4.0	5.0	6.0
30	20	1.055						
40	20	1.289	1.667					
40	30	1.523	1.979	2.409				
50	20	1.523	1.979					
50	25	1.640	2.135	2.604				
50	30	1.757	2.291	2.799				
50	40	1.991	2.603	3.189	3.750			
60	20	1.757	2.291					
60	30	1.991	2.603	3.189				
60	40	2.225	2.915	3.579	4.218	5.419		
60	50	2.459	3.227	3.969	4.686	6.043		
70	50	2.693	3.539	4.359	5.154	6.667		
80	30	2.459	3.227	3.969	4.686			
80	40	2.693	3.539	4.359	5.154	6.667		
80	60		4.163	5.139	6.090	7.915		
100	30		3.851	4.749	5.622			
100	40		4.163	5.139	6.090	7.915		
100	50		4.475	5.529	6.558	8.539		
100	60		4.787	5.919	7.026	9.163	11.197	
100	80		5.411	6.699	7.962	10.411	12.757	
120	40		4.787	5.919	7.026	9.163		
120	60			6.699	7.962	10.411	12.757	
120	80			7.479	8.898	11.659	14.317	
150	100				11.238	14.779	18.217	21.552
200	100				13.578	17.899	22.117	26.232

Sizes marked in **bold** are available in high-strength class STALA630D.

STALA800

EN 1.4678

EN 1.4678 has exceptional combination of high strength and elongation. The material can absorb huge amount of energy in case of an accident which makes it ideal material for roll-over structures and collision guards.

STALA800 is optimal combination of mechanical properties and corrosion resistance. Coating is recommended.

Delivery condition	
Forming	Cold formed (roll-formed)
Welding process	Laser
Weld condition	External weld bead removed

Bundle packing	
Plastic bands	

Tube marking	
Ink-jet marking on tube	Stalutube Oy made in Finland, steel grade, dimensions, coil number, production week/year, welding operator
Bundle tag	Dimensions, steel grade, surface condition, bundle size, batch id, coil number, bundle number

Surface condition	
As welded (unpol)	

Tolerances (according to EN 10219-2)	
Characteristic	Tolerance
Outside dimensions, B and H	B,H < 100 mm: ± 1 %, min ± 0.5 mm B,H ≥ 100 mm: ± 0.8 %
Concavity / Convexity (X ¹ /X ²)	Max. 0.8 % with minimum of 0.5 mm
Wall thickness, T	± 10 %
Squareness of side	90° ± 1°
External corner profile, C1, C2 or R	1.6T – 2.4T
Length	Standard length 6 m, tolerance 0/+20 mm
Straightness	0.15 % of total length
Twist	2 mm + 0.5 mm/m

¹⁾ Exception from standard

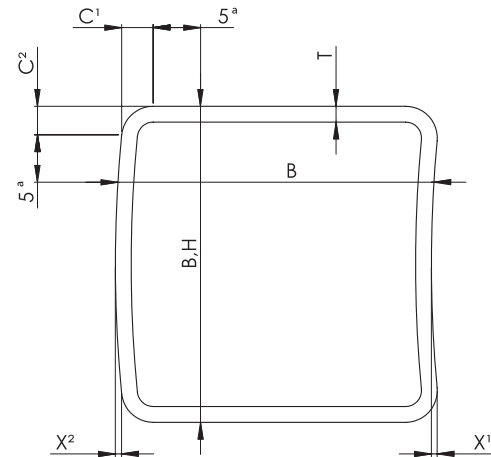

^a This dimension is maximum when measuring B or H and minimum when measuring T

Square		Weight [kg/m]			
H x B [mm]		1.5	2.0	2.5	3.0
25	25	1.05			
30	30	1.29	1.67		
32	32	1.38	1.79		
35	35	1.52	1.98		
40	40	1.76	2.29	2.80	3.28
45	45	1.99	2.60	3.19	3.75
50	50	2.22	2.91	3.58	4.22
55	55	2.46	3.23	3.97	4.69
60	60	2.69	3.54	4.36	5.15
70	70		4.16	5.14	6.09
75	75		4.47	5.53	6.56
80	80			5.92	7.03
90	90			6.70	7.96
100	100			7.48	8.90

Rectangular		Weight [kg/m]			
H x B [mm]		1.5	2.0	2.5	3.0
30	20	1.05			
40	20	1.29	1.67		
40	30	1.52	1.98		
50	20	1.52	1.98		
50	25	1.64	2.13		
50	30	1.76	2.29	2.80	
50	40	1.99	2.60	3.19	3.75
60	20	1.76	2.29		
60	30	1.99	2.60	3.19	
60	40	2.22	2.91	3.58	4.22
60	50	2.46	3.23	3.97	4.69
70	50	2.69	3.54	4.36	5.15
80	30	2.46	3.23	3.97	4.69
80	40	2.69	3.54	4.36	5.15
80	60		4.16	5.14	6.09
100	30		3.85	4.75	5.62
100	40		4.16	5.21	6.17
100	50		4.47	5.53	6.56
100	60		4.79	5.92	7.03
100	80		5.41	6.70	7.96
120	40			5.92	7.03
120	60			6.70	7.96
120	80			7.48	8.90

SPECIAL DIMENSIONS AND
TAILOR-MADE PRODUCTS BY REQUEST

Ferritic and duplex sheets

Delivery condition		Bundle packing
Forming	Hot or cold rolled	Wooden pallets

Tolerances	
EN ISO 9444-2 hot rolled	EN ISO 9445-2 cold rolled

Ferritic sheets EN 1.4003	
W x L [mm]	Thickness [mm]
1250 x 2500 and 1500 x 3000	1.0
	1.2
	1.5
	2.0
	3.0
	4.0
	5.0
	6.0
	8.0
	10.0

Lean Duplex sheets EN 1.4162	
W x L [mm]	Thickness [mm]
1500 x 3000	1.5
	2.0
	3.0
	4.0
	5.0
	6.0

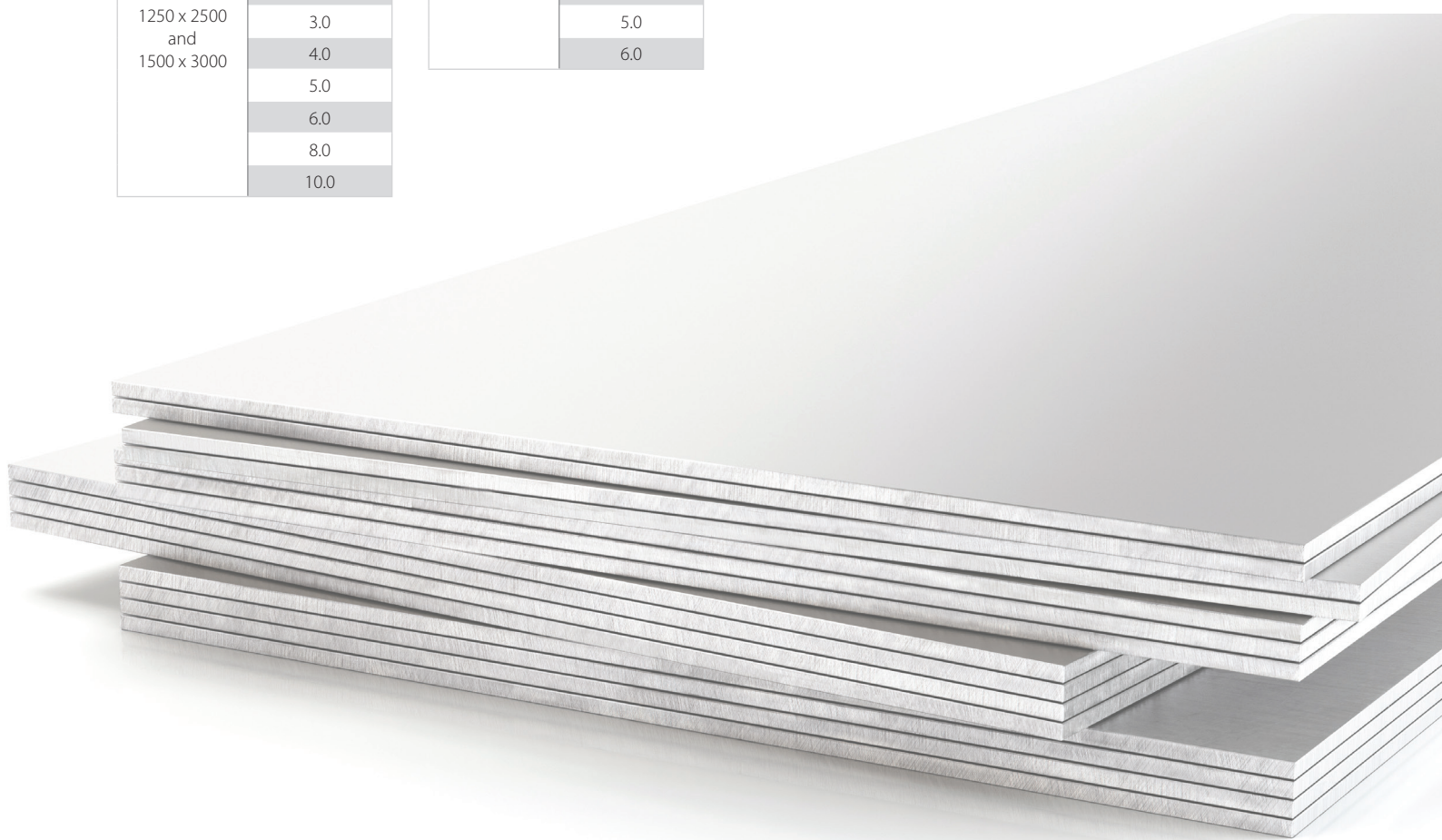

Tailor-made products | Versatile design possibilities | Stocking service
Short delivery time | High energy absorption properties
Special dimensions can be ordered by request

USE OUR STRENGTH

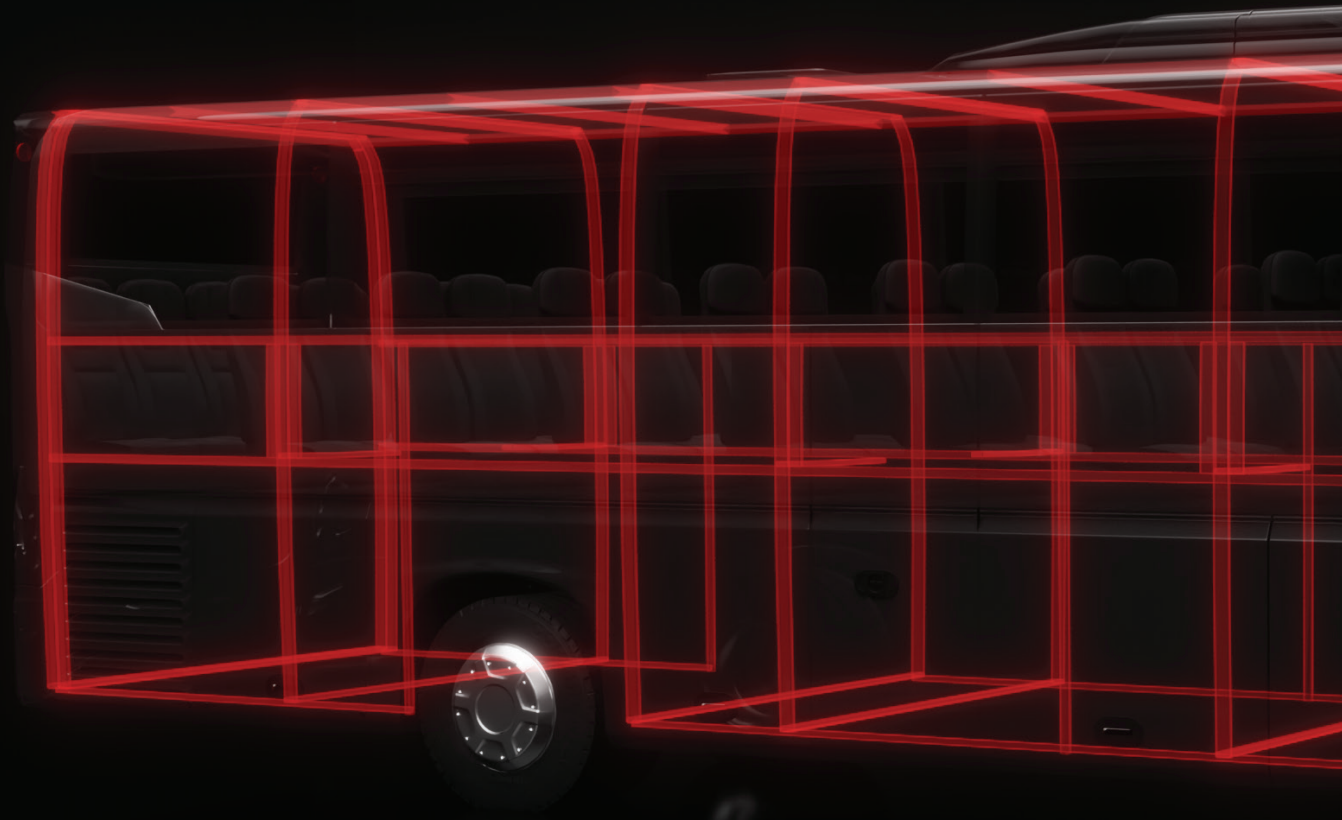

The best stainless steel solutions to answer your needs.

Over the past 50 years, we've gained the expertise, created the world's widest range of hollow sections and developed a global distribution network to be able to serve you in all corners of the globe, even in the most demanding projects and applications.

Stal tube Oy Taivalkatu 7, 15170 Lahti FINLAND | Tel. +358 3 882 190 | sales@stal tube.com | stal tube.com

STAL
TUBE