

**STALA**  
TUBE

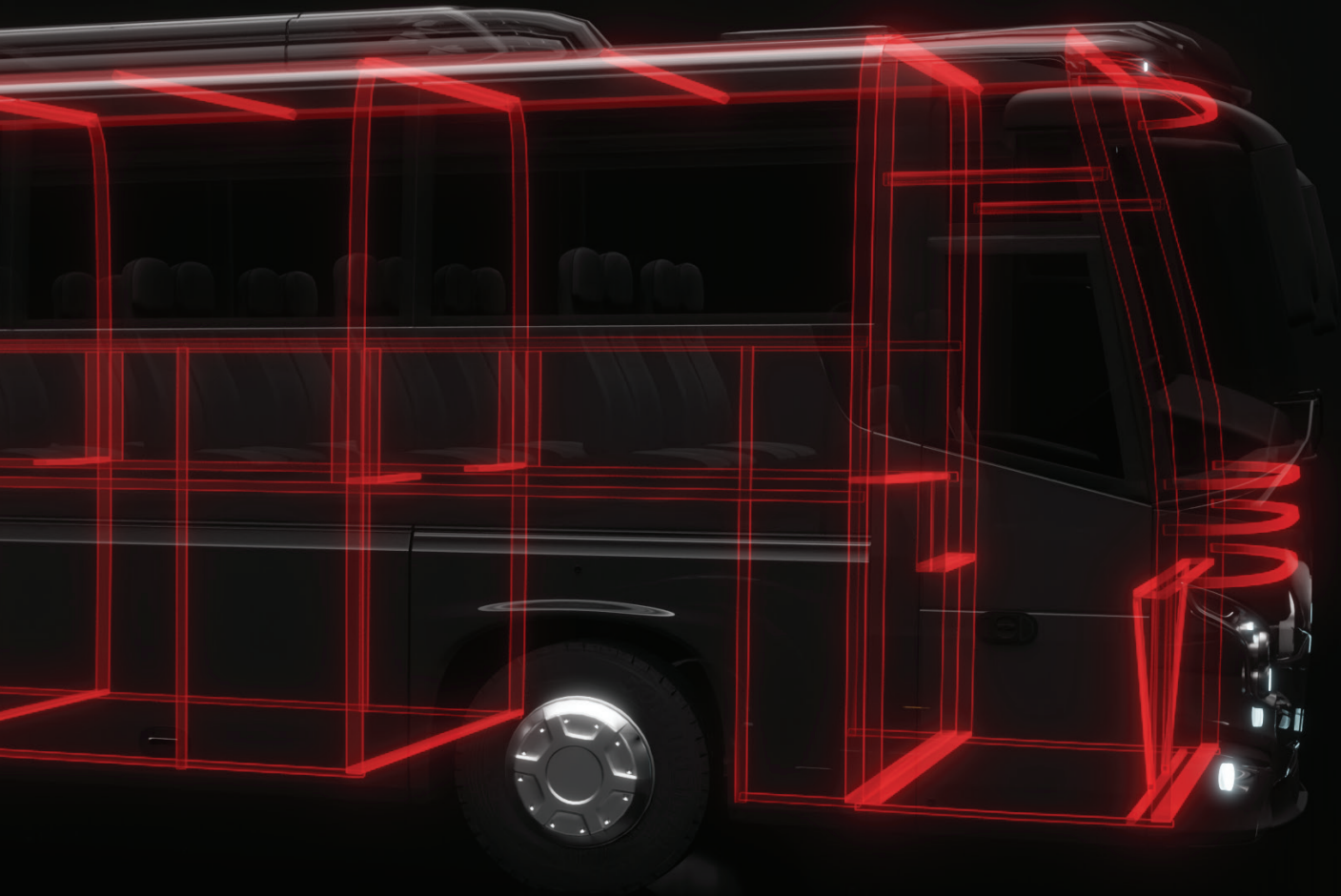

DATASHEET **IMPERIAL**

Stainless Steel Lightweight Solutions  
for Transportation Industry

# Stalatube stainless steel lightweight solutions

## Tubes, sheets and components for bus bodies, chassis, collision guards and cabin structural parts

Stalatube's product portfolio contains standard and fully custom-made square and rectangular tubes, tube components, sheets, and welded structures. Laser cutting, bending, and creating ready-to-assemble component kits are at the core of our services for the transport industry. Lead time is reduced through flexible stocking and delivery options.

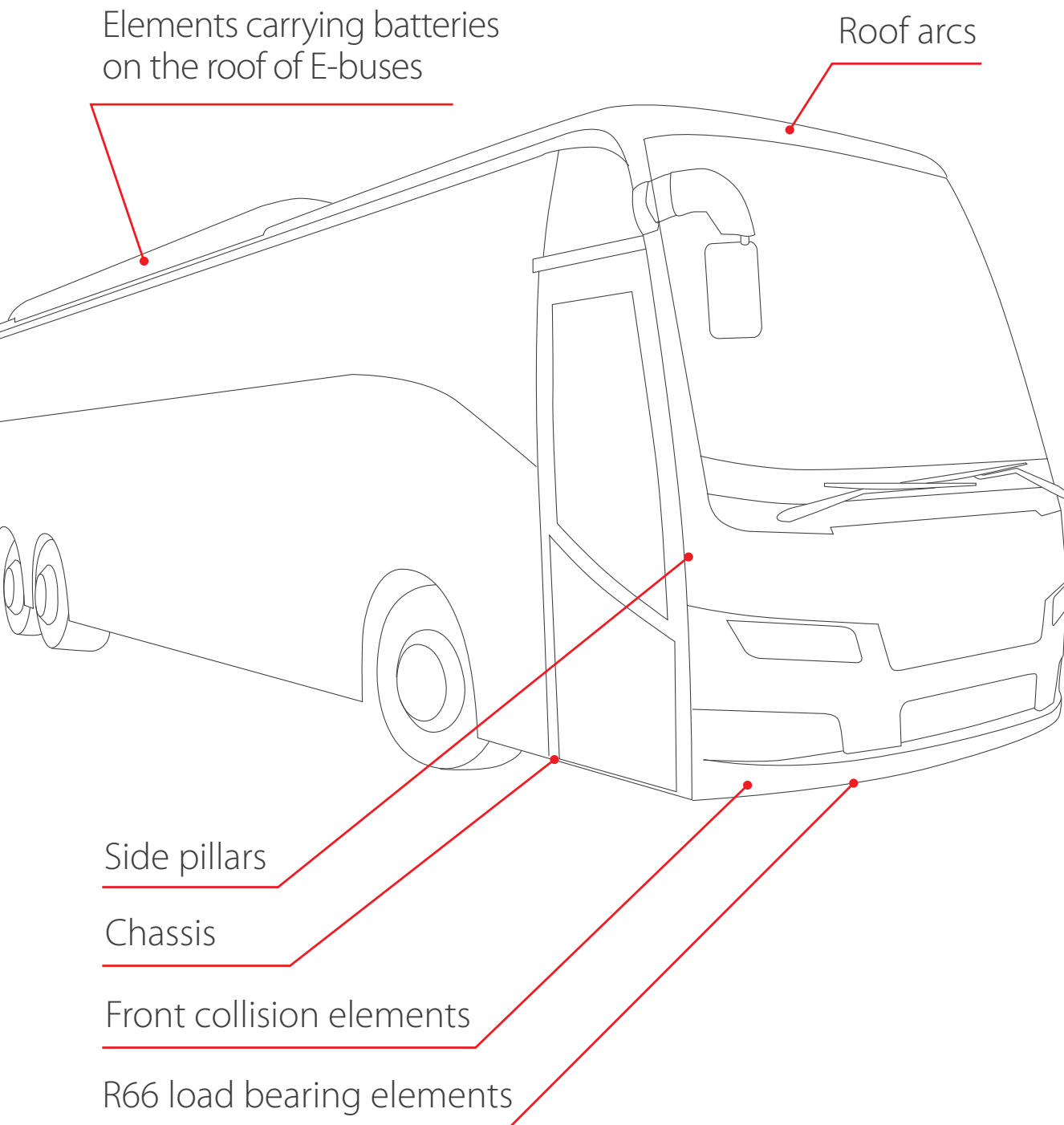

# Stainless steel lightweight solutions

In transportation sector the ultimate goal is clear – lighter vehicles with lower CO<sub>2</sub> emissions paired with the very highest occupant safety. Stalatube's innovative high strength stainless steel materials and optimal vehicle structure design help achieve the weight reduction necessary as well as to meet CO<sub>2</sub> goals.

## **Achieve your carbon footprint goals**

Stainless steel is 100 % recyclable. It is the most recycled material in the world, and its quality is preserved in the process. Using stainless steel decreases your own as well as your customer's carbon footprint.

---

## About Stalatube

Stalatube is a manufacturer of highly developed stainless steel hollow sections, profiles and components. We are known worldwide as the leading provider of stainless steel solutions. With a global presence, in-depth material expertise and the world's widest product portfolio in stainless square and rectangular hollow sections, we help customers connect the most suitable product with their application or project - in even the most complex of cases. Our customizable, environmentally conscious solutions are here to build a better future. We believe that by working with customers and investing in R&D, anything is possible.

For over 50 years of pioneer work in the industry, we have built an international distribution network covering all continents and over 50 countries. Our head office and main production facility is in Finland, sales offices are in the USA and Netherlands, a R&D office in Turkey, and a production facility for further processed products in Poland. To assist you in being the best, we provide world-class stainless steel know-how, cutting-edge technology and a full range of professional services.

## **USE OUR STRENGTH!**



# STALA Opti

## The new reinforced tube with optimized strength, fatigue, and stiffness properties

The STALA Opti tube offers an excellent combination of flexural strength and light weight. Heavier wall thickness at the end of the tube allows better weld penetration and improved fatigue strength in welded tube joints. Reinforcement inside the tube significantly increases buckling resistance.

The optimal solution in those areas of the bus body structure where stiffness is required. STALA Opti offers excellent flexural strength for our customers looking for strength and durability without weight increase and stronger joints. This is a unique solution to strengthen the required area while eliminating the weight increase and is mainly suitable for bus body structures.

STALA Opti is available in all stainless steel grades in Stalatable's product portfolio.

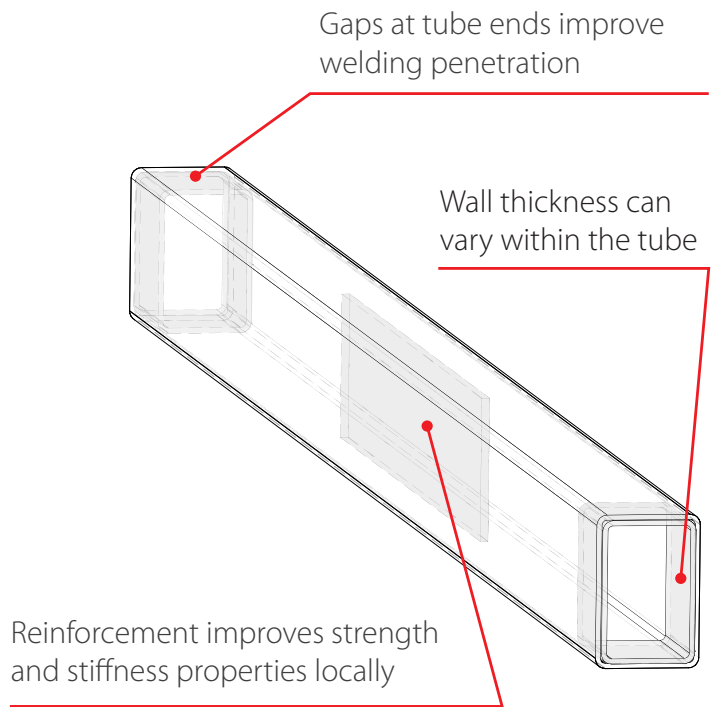

Reinforced tube STALA Opti 2.36" x 1.57" x 0.08"

High flexural strength and buckling resistance | Avoid problems related to welding of thin wall thicknesses | Big weight-saving potential

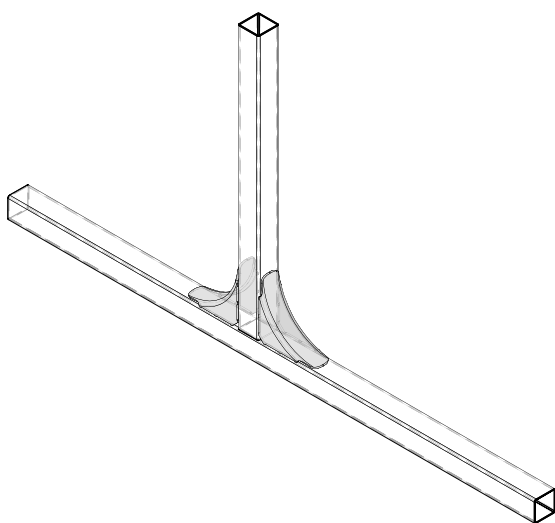

STALA Connect T joint tube 2" x 2" x 0.08"

# STALA Connect

## Longer welding line, enhanced force distribution, and extreme fatigue life with joint parts

STALA Connect is designed to improve the fatigue strength of welded tube connections. It can be used in L, T and X joints. STALA Connect allows loads to be transferred further away from the joint. STALA Connect offers many times the fatigue strength of traditional joints.

Axial stress -78 % | Bending stress -58 % | Improved fatigue resistance

# Use our special consultation service

How to design the most lightweight vehicle body?

Our team has a long technical experience and know-how in bus body design. Major savings in total weight of a vehicle can be achieved by optimizing the bus body structure. We are here to help our customers to choose the right materials and products to maximize the benefits of stainless steel.

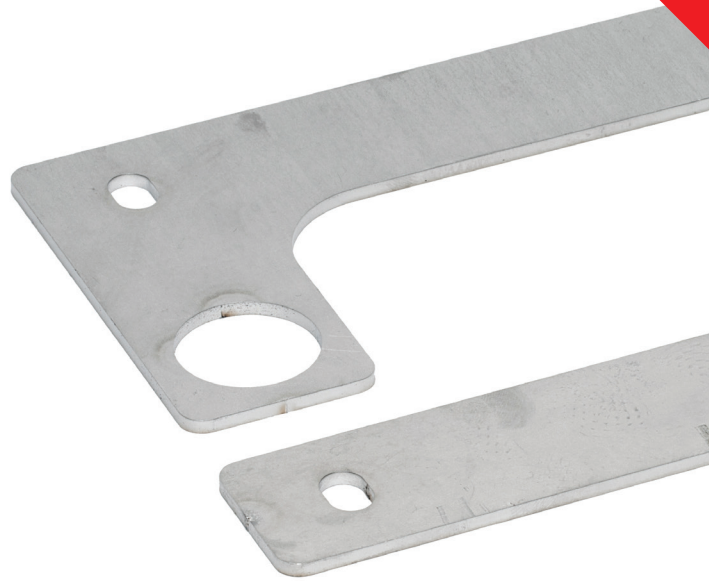

## Tolerances

<b>Cut to length service</b>	13 - 60 ft, tolerance -0" /+ .78"
<b>Precise cutting</b>	0.78" - 29.5 ft, tolerance $\pm 0.04"$ $\geq 29.5$ ft, tolerance depends on the length
<b>Angle cutting</b>	30-90°, tolerance $\pm 1^\circ$
<b>Laser cutting</b>	Tolerance $\pm 0.02"$

## Mechanical properties

Mechanical properties of tubes						
Strength class	Steel grade	EN	UNS	0.2 % - proof strength Rp0.2 ksi (MPa)	Tensile strength Rm ksi (MPa)	Elongation in 2 in. or 50 mm min., %
Standard 1.4003	4003	1.4003	S40977	41 (280)	65 (450)	10
STALA400F	4003	1.4003	S40977	58 (400)	65 (450)	10
Standard 1.416 T > 0.187 in. (5 mm)	LDX2101	1.4162	S32101	65 (450)	94 (650)	20
STALA630D	LDX2101	1.4162	S32101	91 (630)	108 (750)	20
STALA800	H800	1.4678	-	116 (800)	145 (1000)	25
Sheets	4003	1.4003	S40977	41 (280)	65-94 (450-650)	20
Sheets	LDX2101	1.4162	S32101	65 (450)	94-130 (650-900)	30

## Chemical composition

Chemical composition (% by mass, maximum values unless indicated otherwise)												
Steel grade	EN	UNS	C	Si	Mn	P	S	N	Cr	Mo	Ni	Other
4003	1.4003	S40977	0.030	1.00	1.50	0.040	0.015	0.030	10.5-12.5		0.30-1.00	
LDX2101	1.4162	S32101	0.040	1.00	4.00-6.00	0.040	0.015	0.20-0.25	21.0-22.0	0.10-0.80	1.35-1.70	Cu 0.10-0.80
STALA800	1.4678	-	0.20-0.40	1.00	14.0-18.0	0.045	0.015	0.20-0.40	12.0-16.0	-	-	-

Chemical composition and mechanical properties of material fulfill the standard EN 10088-2.



# Ferritic

## S40977

S40977 offers the benefits of more highly alloyed stainless steels such as strength, corrosion and abrasion resistance, durability and low maintenance. It is weldable and formable

allowing it to be fabricated using conventional techniques. Ferritic is also cost-efficient choice.

Delivery condition	
Forming	Cold formed (roll-formed)
Welding process	Laser or HF
Weld condition	External weld bead removed

Bundle packing	
Plastic bands	

Tube marking	
Ink-jet marking on tube	Stalutube Oy made in Finland, steel grade, dimensions, coil number, production week/year, welding operator
Bundle tag	Dimensions, steel grade, surface condition, bundle size, batch id, coil number, bundle number

Surface condition	
As welded (unpol)	

Tolerances	
Characteristic	Tolerance
Outside dimensions, B and H	B,H < 4": ± 1%, min ± .02", B,H ≥ 4": ± 0.8 %
Concavity / Convexity	Max. 0.8 % with minimum of 0.02"
Wall thickness, T	± 10 %
Squareness of side	90° ± 1°
External corner profile (C1, C2 or R)	1.6T - 2.4T
Length	Standard length 20' tolerance -0"/+ 0.78" <sup>1)</sup>
Straightness	0.15 % of total length
Twist	0.08" + .02"/ft

<sup>1)</sup> Exception from standard

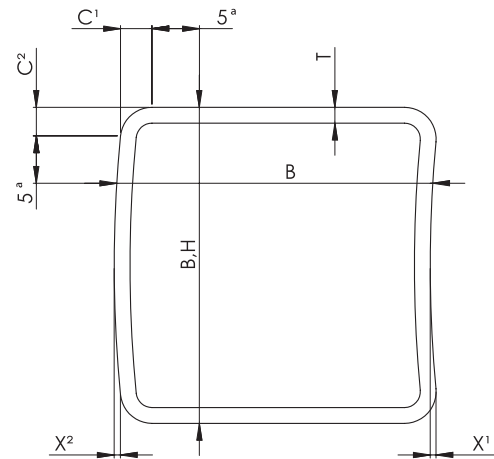
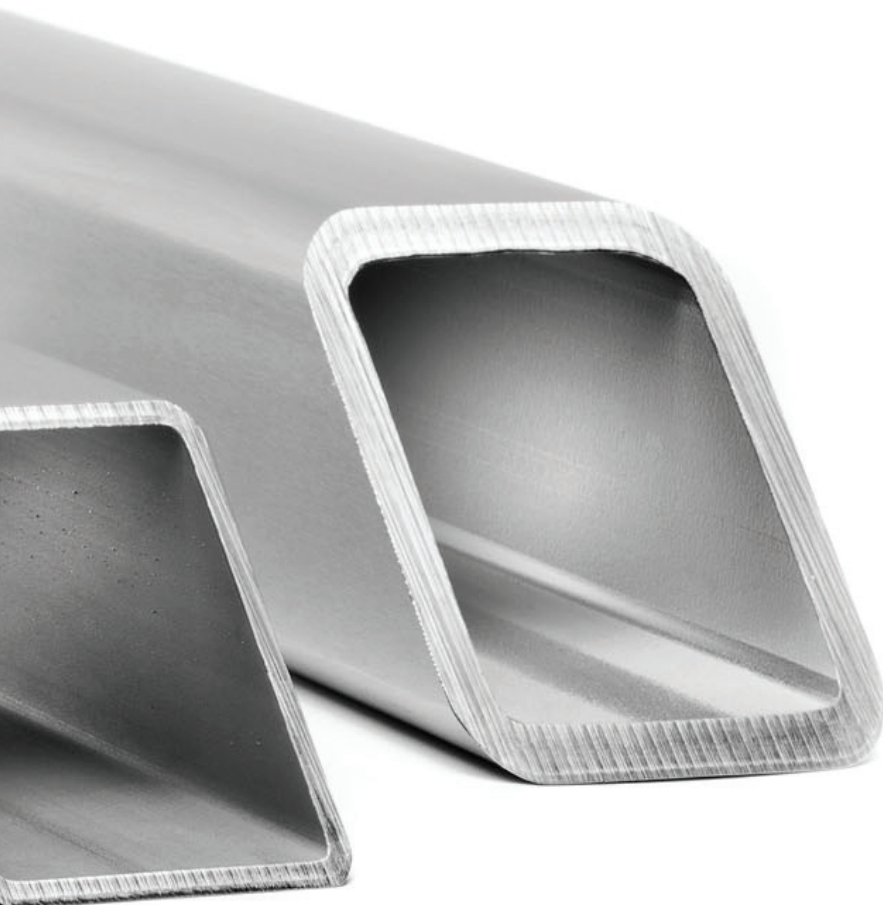

<sup>a</sup> This dimension is maximum when measuring B or H and minimum when measuring T

Square		Weight [kg/m]				
H x B [in.]		0.06	0.08	0.12	0.18	0.25
1	1	<b>0.722</b>	<b>0.928</b>			
1.25	1.25	<b>0.922</b>	<b>1.195</b>	<b>1.687</b>		
1.5	1.5	<b>1.123</b>	<b>1.462</b>	<b>2.087</b>		
2	2	1.523	<b>1.996</b>	<b>2.888</b>		
2.5	2.5			<b>3.690</b>	<b>5.297</b>	
3	3			<b>4.491</b>	<b>6.499</b>	
3.5	3.5			<b>5.292</b>	<b>7.701</b>	<b>10.311</b>
4	4			<b>6.093</b>	<b>8.902</b>	<b>11.980</b>

Sizes marked in **bold** are available in high-strength class STALA400F.

Rectangular		Weight [kg/m]				
H x B [in.]		0.06	0.08	0.12	0.18	0.25
1.5	1	<b>0.922</b>	<b>1.195</b>			
2	1	<b>1.123</b>	<b>1.462</b>			
2	1.5	<b>1.323</b>	<b>1.729</b>	<b>2.488</b>		
2.5	1	<b>1.323</b>	<b>1.729</b>			
2.5	1.5	<b>1.523</b>	<b>1.996</b>	<b>2.888</b>		
3	1	1.523	<b>1.996</b>			
3	2		2.530	<b>3.690</b>	<b>5.297</b>	
4	2		3.064	<b>4.491</b>	<b>6.499</b>	
4	3		3.598	<b>5.292</b>	<b>7.701</b>	<b>10.311</b>
5	3			6.093	<b>8.902</b>	<b>11.980</b>

Sizes marked in **bold** are available in high-strength class STALA400F.

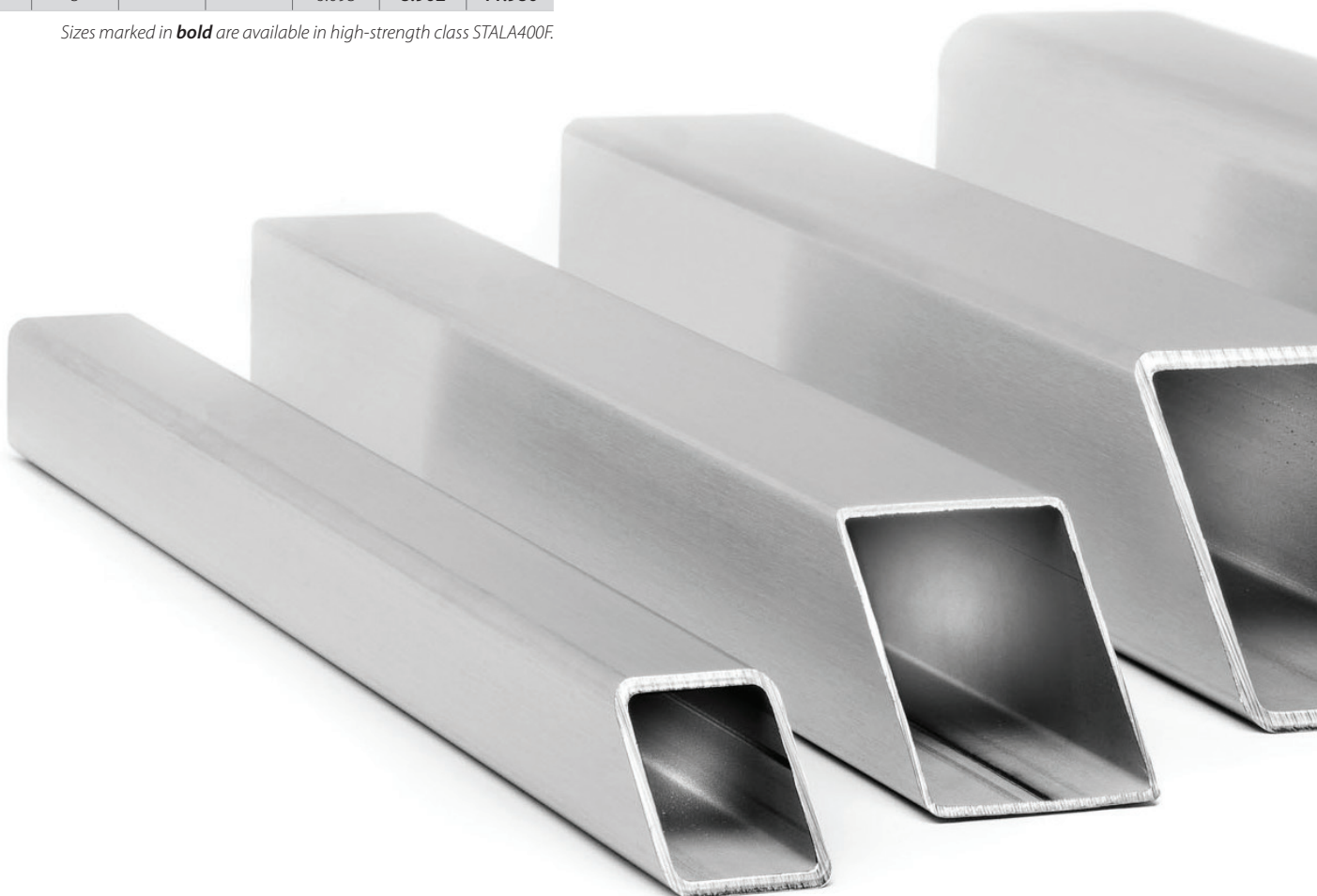

# Lean Duplex

## S32101

S32101 grade answers to the most demanding needs by offering a superior combination of high strength and elongation, corrosion resistance and lowered life cycle costs.

Duplex is optimal material used in side pillars, roof arcs, R66 structures and collision guard elements. It can be combined with other materials such as ferritic S40977.

Delivery condition	
Forming	Cold formed (roll-formed)
Welding process	TIG/Plasma or Laser
Weld condition	External weld bead removed

Bundle packing	
Plastic bands	

Tube marking	
Ink-jet marking on tube	Stalutube Oy made in Finland, steel grade, dimensions, coil number, production week/year, welding operator
Bundle tag	Dimensions, steel grade, surface condition, bundle size, batch id, coil number, bundle number

Surface condition	
Brushed, when tube dimension is $\leq 4" \times 4" \times 0.25"$	
As welded (unpol), when tube dimension is $> 4" \times 4" \times 0.25"$	

Tolerances	
Characteristic	Tolerance
Outside dimensions, B and H	B, H < 4": $\pm 1\%$ , min $\pm 0.02"$ B, H $\geq 4$ ": $\pm 0.8\%$ "
Concavity / Convexity (X <sup>1</sup> /X <sup>2</sup> )	Max. 0.8 % with minimum of 0.2"
Wall thickness, T	$\pm 10\%$
Squareness of side	$90^\circ \pm 1^\circ$
External corner profile, C1, C2 or R	B + H $\leq 8$ ": 1.5T - 2.5T B + H > 8" and T $\leq 0.16$ " 2T - 3T B + H > 8" and T > 0.16": 1.5T - 2.5T
Length	"Standard length 20' tolerance -0"/+ 0.78"
Straightness	0.15 % of total length
Twist	0.08" + 0.02"/ft

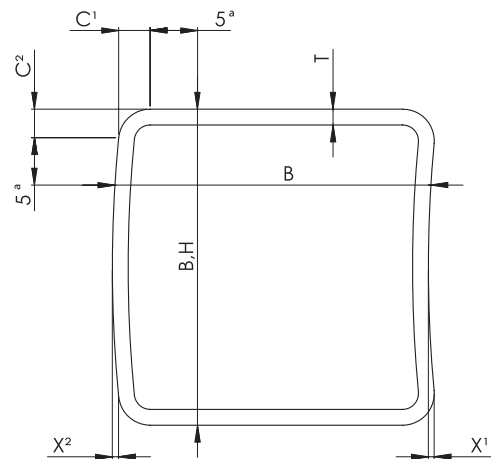

<sup>a</sup> This dimension is maximum when measuring B or H and minimum when measuring T



Square		Weight [LB/FT]					
H x B [in.]		0.060	0.080	0.120	0.180	0.250	0.312
1	1	<b>0.731</b>	<b>0.940</b>				
1.25	1.25	<b>0.934</b>	<b>1.210</b>				
1.5	1.5	<b>1.137</b>	<b>1.481</b>				
2	2	<b>1.543</b>	<b>2.022</b>	<b>2.926</b>			
2.5	2.5		<b>2.563</b>	<b>3.737</b>			
3	3		<b>3.104</b>	<b>4.549</b>			
3.5	3.5			<b>5.361</b>	<b>7.801</b>		
4	4			<b>6.172</b>	<b>9.018</b>	12.135	
5	5			7.795	11.453	15.517	
6	6			9.418	13.887	18.898	
8	8				18.757	25.662	31.595
10	10					32.425	40.035
12	12					39.188	48.476

Sizes marked in **bold** are available in high-strength class STALA630D.

Rectangular		Weight [LB/FT]					
H x B [in.]		0.060	0.080	0.120	0.180	0.250	0.312
1.5	1	<b>0.934</b>	<b>1.210</b>				
2	1	<b>1.137</b>	<b>1.481</b>				
2	1.5	<b>1.340</b>	<b>1.751</b>	<b>2.520</b>			
3	1	<b>1.543</b>	<b>2.022</b>				
3	2		<b>2.563</b>	<b>3.737</b>			
4	2		3.104	<b>4.549</b>			
4	3		3.645	<b>5.361</b>			
6	4			7.795	11.453	15.517	
8	4			9.418	13.887	18.898	
10	6				18.757	25.662	
12	4				18.757	25.662	
12	8					32.425	40.035
16	8					39.188	48.476

Sizes marked in **bold** are available in high-strength class STALA630D.

# STALA800

## EN 1.4678

EN 1.4678 has exceptional combination of high strength and elongation. The material can absorb huge amount of energy in case of an accident which makes it ideal material for roll-over structures and collision guards.

STALA800 is optimal combination of mechanical properties and corrosion resistance. Coating is recommended.

Delivery condition	
Forming	Cold formed (roll-formed)
Welding process	Laser
Weld condition	External weld bead removed

Bundle packing	
Plastic bands	

Tube marking	
Ink-jet marking on tube	Stalutube Oy made in Finland, steel grade, dimensions, coil number, production week/year, welding operator
Bundle tag	Dimensions, steel grade, surface condition, bundle size, batch id, coil number, bundle number

Surface condition	
As welded (unpol)	

Tolerances (according to EN 10219-2)	
Characteristic	Tolerance
Outside dimensions, B and H	B,H < 4": ± 1%, min ± .02", B,H ≥ 4": ± 0.8 %
Concavity / Convexity (X <sup>1</sup> /X <sup>2</sup> )	Max. 0.8 % with minimum of 0.02"
Wall thickness, T	± 10 %
Squareness of side	90° ± 1°
External corner profile (C1, C2)	1.5T - 2.5T
Length	Standard length 20' Tolerance -0"/+ .78"
Straightness	0.15 % of total length
Twist	0.08" + 0.02"/ft

<sup>1)</sup> Exception from standard

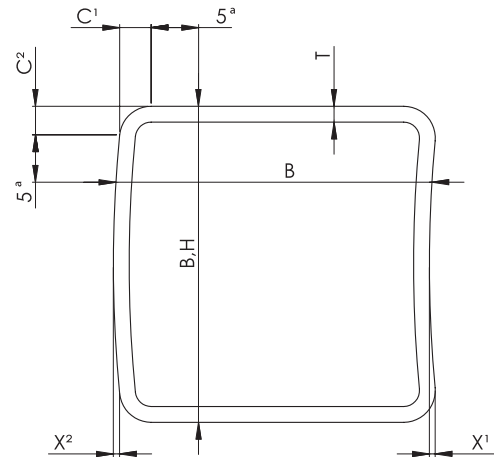

<sup>a</sup> This dimension is maximum when measuring B or H and minimum when measuring T

Rectangular		Weight [LB/FT]		
H x B [in.]		0.60	0.80	0.120
1.5	1	0.932	1.207	
2	1	1.134	1.477	
2	1.5	1.337	1.747	
2.5	1	1.337	1.747	
2.5	1.5	1.539	2.017	
3	1	1.539	2.017	
3	2		2.556	3.728
4	2		3.096	4.537
4	3		3.636	5.347
5	3			6.156

Square		Weight [LB/FT]		
H x B [in.]		0.60	0.80	0.120
1	1	0.730		
1.25	1.25	0.932	1.207	
1.5	1.5	1.134	1.477	
2	2	1.539	2.017	2.918
2.5	2.5		2.556	3.728
3	3		3.096	4.537
3.5	3.5			5.347

SPECIAL DIMENSIONS AND  
TAILOR-MADE PRODUCTS BY REQUEST

# Ferritic and duplex sheets

Delivery condition		Bundle packing
Forming	Hot or cold rolled	Wooden pallets

Tolerances	
EN ISO 9444-2 hot rolled	EN ISO 9445-2 cold rolled

Ferritic sheets S40977	
W x L [mm]	Thickness [mm]
1250 x 2500 and 1500 x 3000	1.0
	1.2
	1.5
	2.0
	3.0
	4.0
	5.0
	6.0
	8.0
	10.0

Lean Duplex sheets S32101	
W x L [mm]	Thickness [mm]
1500 x 3000	1.5
	2.0
	3.0
	4.0
	5.0
	6.0

*\* Please note that all the sheet dimensions are according to the metric system.*

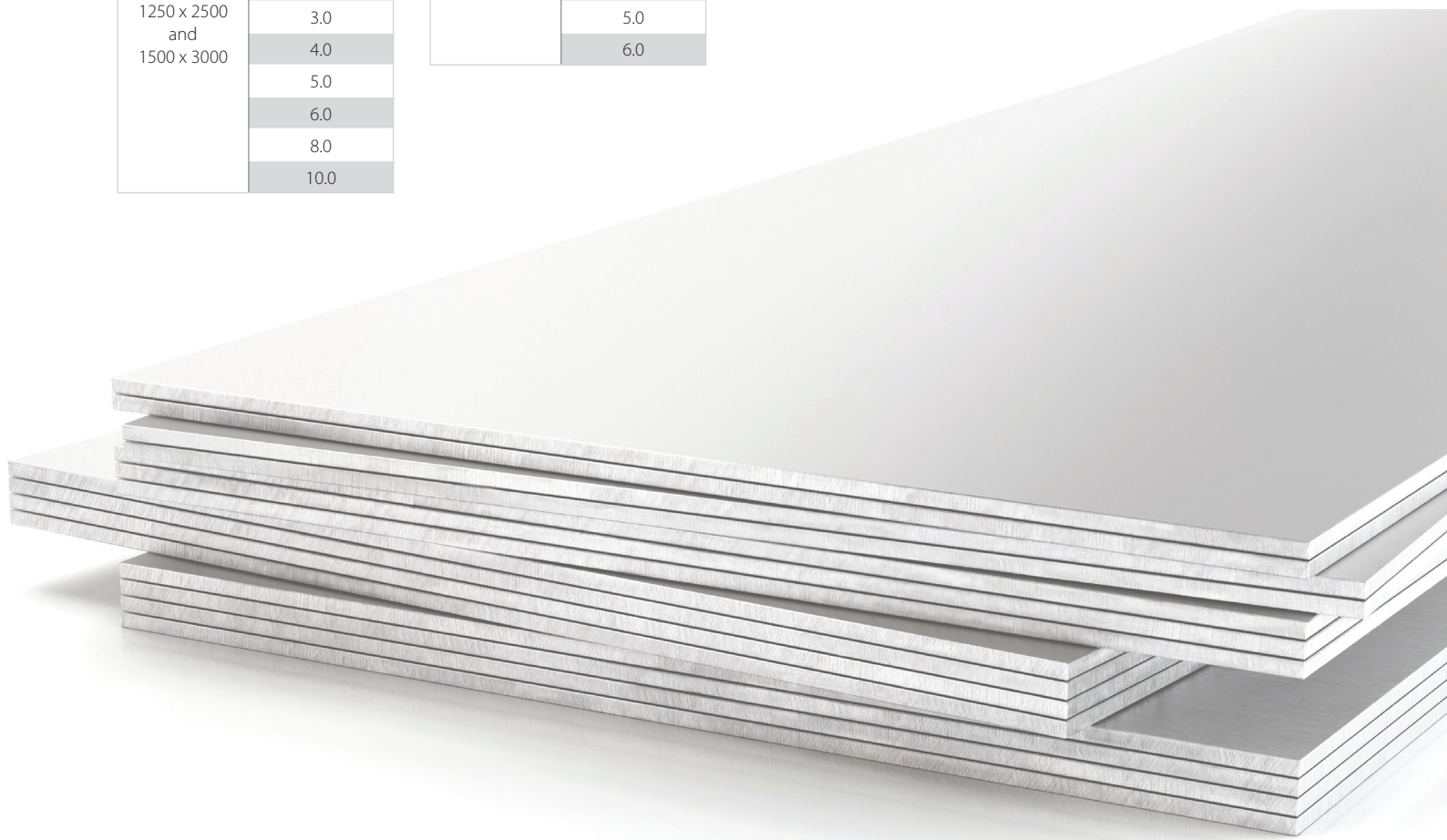

Tailor-made products | Versatile design possibilities | Stocking service  
Short delivery time | High energy absorption properties  
Special dimensions can be ordered by request

USE OUR STRENGTH

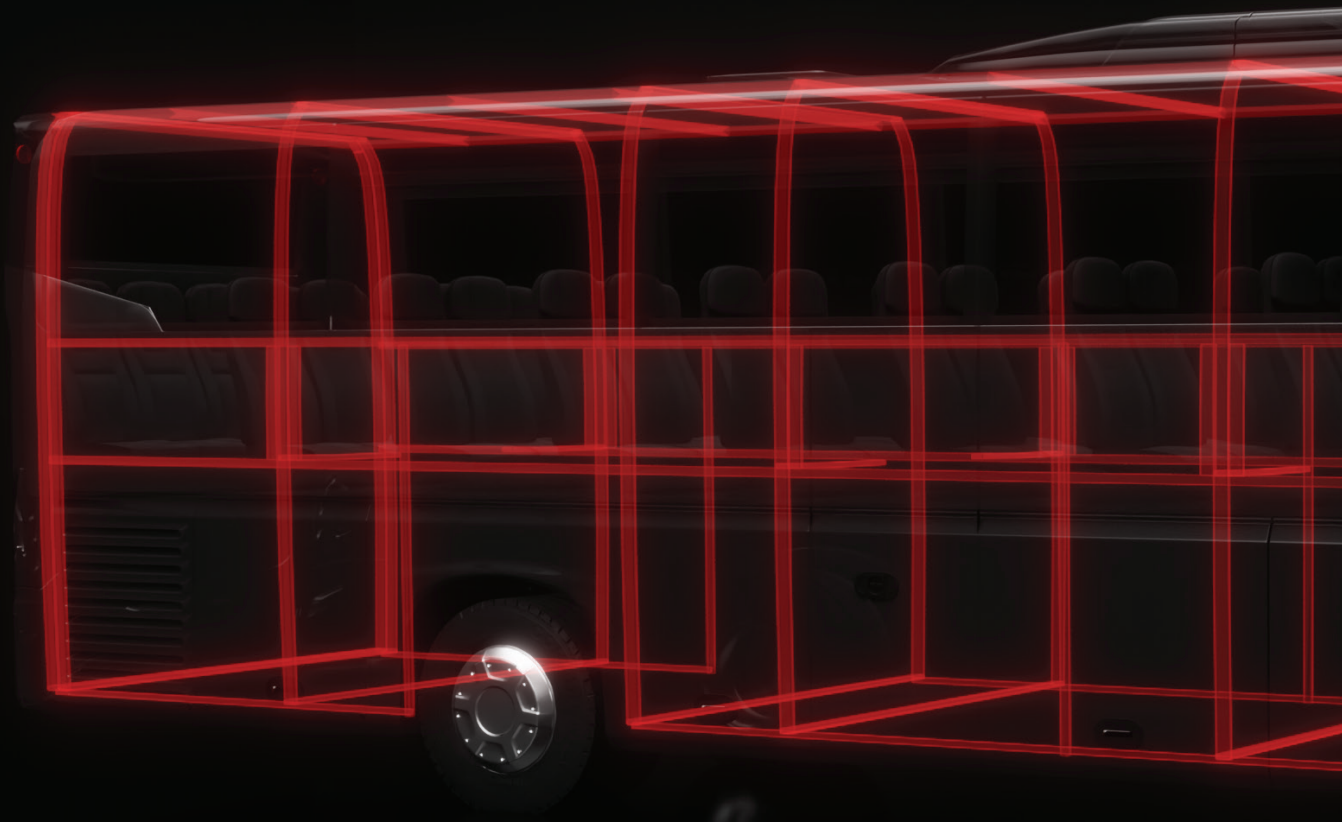

## The best stainless steel solutions to answer your needs.

Over the past 50 years, we've gained the expertise, created the world's widest range of hollow sections and developed a global distribution network to be able to serve you in all corners of the globe, even in the most demanding projects and applications.

Stal tube Oy Taivalkatu 7, 15170 Lahti FINLAND | Tel. +358 3 882 190 | [sales@stal tube.com](mailto:sales@stal tube.com) | [stal tube.com](http://stal tube.com)

**STAL**  
TUBE